

Pressure Independent Control Series

Two-Way, Brass and Ductile Iron Valve Bodies, 1/2-Inch to 2-Inch, ANSI 250
Used with SSD81..., SSD61..., SAY, and Rack & Pinion Actuators

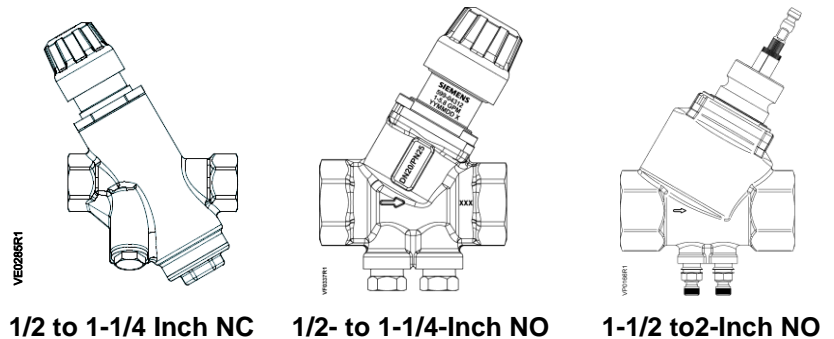

Description

Siemens Pressure Independent Control Valves integrate three functions into a single device: control valve, adjustable flow limiter, and automatic pressure regulator. The 1/2- to 1-1/4-inch Normally Open and 1/2 to 1-1/4 inch Normally Closed Valves have a 5- or 5.5-mm stroke, and a threaded valve bonnet for use with SSD81... and SSD61... Electronic Valve Actuators. The 1-1/2- and 2-inch Normally Open Valves have a 15-mm stroke and use the SAY61.03U Modulating Electronic Valve Actuator or the Rack and Pinion linkage and Siemens Open Air® GPC spring return damper actuators.

Features

- Control valve with integrated pressure regulator and adjustable flow limiter.
- ANSI Class 250 valve body.
- 200 psi close-off with ANSI Class IV leakage (1/2 to 1-1/4-inch Normally Open).
- 100 psi close-off with ANSI Class IV leakage (1-1/2- and 2-inch Normally Open).
- 45 psi close-off with ANSI Class IV leakage (1/2 to 1-1/4 inch Normally Closed).
- Linear Flow Characteristic.
- Stainless Steel Stem.
- 1/2- to 1-1/4-inch valves do NOT include P/T ports. If P/T ports are required, the 599-10079 P/T ports accessory kit must be ordered separately (see *Accessory*).
- 1-1/2- and 2-Inch Valves include P/T ports.
- SAY61.03U actuators for 1-1/2- and 2-inch Normally Open Valves can also be set for Normally Closed operation (reverse acting). See note on page 2.

Application

For use in HVAC applications with Pressure Independent Control SSD81...and SSD61..., SAY or Rack and Pinion Electronic Actuators, to control hot or chilled water or 50% water-glycol solution in closed loop systems.

Product Numbers and Ordering

Valves can be ordered with or without an actuator assembly from the factory. See all orderable valve part numbers in Table 1. For all valve/actuator assembly part numbers, see *Pressure Independent Control 2-Way Valves and Electronic Valve Actuators Submittal Sheet (154-087)*.

Caution Notations

CAUTION:		Equipment damage may occur if you do not perform a procedure as specified.
-----------------	--	--

Product Numbers

Table 1. Product Numbers.

Line Size	Factory Preset Max GPM	Normally Closed	Normally Open
1/2 (15)	0.5	599-04300-0.5	599-04320-0.5
	1	599-04300-1	599-04321-1
	1.5	599-04300-1.5	599-04321-1.5
	2	599-04300-2	599-04321-2
	2.5	599-04300-2.5	599-04321-2.5
	3	599-04301-3	599-04321-3
	3.5	599-04301-3.5	599-04321-3.5
	4	599-04301-4	599-04321-4
	4.5	599-04301-4.5	599-04321-4.5
	5	599-04301-5	599-04321-5
	5.5	599-04301-5.5	599-04321-5.5
	6	599-04301-6	—
	6.5	599-04301-6.5	—
	7	599-04301-7	—
	7.5	599-04301-7.5	—
3/4 (20)	1	599-04302-1	—
	1.5	599-04302-1.5	—
	2	599-04302-2	599-04322-2
	2.5	599-04302-2.5	599-04322-2.5
	3	599-04302-3	599-04322-3
	3.5	599-04302-3.5	599-04322-3.5
	4	599-04302-4	599-04322-4
	4.5	599-04302-4.5	599-04322-4.5
	5	599-04303-5	599-04322-5
	5.5	599-04303-5.5	599-04322-5.5
	6	599-04303-6	599-04322-6
	6.5	599-04303-6.5	599-04322-6.5
	7	599-04303-7	599-04322-7
3/4 (20)	7.5	599-04303-7.5	599-04322-7.5
	8	599-04303-8	599-04322-8
	8.5	599-04303-8.5	—

Line Size	Factory Preset Max GPM	Normally Closed	Normally Open	
1 (25)	4	599-04304-4	—	
	5	599-04304-5	599-04323-5	
	6	599-04304-6	599-04323-6	
	7	599-04304-7	599-04323-7	
	8	599-04304-8	599-04323-8	
	9	599-04304-9	599-04323-9	
	10	—	599-04323-10	
	11	—	599-04323-11	
	12	—	599-04323-12	
	13	—	599-04323-13	
	14	—	599-04323-14	
	15	—	599-04323-15	
	16	—	599-04323-16	
	1-1/4 (32)	9	599-04305-9	599-04314-9
		10	599-04305-10	599-04314-10
		11	599-04305-11	599-04314-11
12		599-04305-12	599-04314-12	
13		599-04305-13	599-04314-13	
14		—	599-04314-14	
15		—	599-04314-15	
16		—	599-04314-15	
17		—	599-04314-17	
18		—	599-04314-18	

Product Numbers, Continued

Line Size	Factory Preset Max GPM	Normally Closed	Normally Open
1-1/2 (40)	15	599-04315-15**	599-04315-15
	20	599-04315-20**	599-04315-20
	25	599-04315-25**	599-04315-25
	30	599-04315-30**	599-04315-30
	35	599-04315-35**	599-04315-35
	40	599-04315-40**	599-04315-40
2 (50)	30	599-04316-30**	599-04316-30
	35	599-04316-35**	599-04316-35
	40	599-04316-40**	599-04316-40
	45	599-04316-45**	599-04316-45
	50	599-04316-50**	599-04316-50

**The 1-1/2" and 2" valves do not have a Normally Closed valve body option. You can change from Normally Open to Normally Closed operation by rewiring the actuator. [See *SAY Electronic Valve Actuator, NSR, 24 Vac Proportional Control Technical Instructions (155-580)* and *SAY Electronic Valve Actuator Installation Instructions (129-583)* for reverse-acting (Normally Closed) operation wiring instructions.]

The Rack & Pinion actuator comes in both a normally open and normally closed configuration for spring return applications. [See *Pressure Independent Control Series Rack & Pinion Technical Instructions (A6V11637981)* and *Installation Instructions (A6V11611545)*.

Specifications

Line sizes	1/2- to 2-inch (15 to 50 mm)
Capacity	See Table 2
Body style	2-way
Action	Normally Closed and Normally Open
Valve body rating	ANSI Class 250
Connection	Internal NPT thread
Rangeability	≥ 100:1
Stem travel (Stroke)	
1/2-inch NO (599-04320, 599-04321)	5 mm
1/2- to 1-1/4-inch NC	5 mm
3/4- to 1-1/4-inch NO	5.5 mm
1-1/2- to 2-inch NO	15 mm

Table 2. Valve Body Flow Range.

Action	Valve Body	Line Size, Inch (mm)	GPM Flow Range
Normally Closed	599-04300	1/2 (15)	0.3 to 2.7
	599-04301		1.0 to 7.5
	599-04302	3/4 (20)	0.5 to 4.5
	599-04303		1.0 to 8.9
	599-04304	1 (25)	1.0 to 8.9
	599-04305	1-1/4 (32)	2.5 to 13.2
Normally Open	599-04320	1/2 (15)	0.3 to 1.6
	599-04321		1.0 to 5.8
	599-04322	3/4 (20)	1.3 to 8
	599-04323	1 (25)	2.6 to 16
	599-04314	1-1/4 (32)	3 to 18
	599-04315	1-1/2 (40)	10 to 40
	599-04316	2 (50)	10 to 50

Material	Body	1/2- to 1-1/4-inch 1-1/2- and 2-inch	DZR Brass CW602N Ductile Iron GJS-400
	Differential Pressure Controller		PPS 40% glass
	Diaphragm		HNBR
	O-rings		EPDM
	Plug		Brass
	Stem, spring		Stainless Steel
	Operating	Controlled medium	
Medium temperature range			34°F to 248°F (1°C to 120°C)
Leakage rate			
1/2- to 1-1/4-inch NO			ANSI Class IV (0.01%) @ 200 psi
1-1/2- and 2-inch NO			ANSI Class IV (0.01%) @ 100 psi
1/2- to 1-1/4-inch NC			ANSI Class IV (0.01%) @ 45 psi
Flow characteristics			Linear
Pressure regulation flow accuracy		+/- 5%	
Range of Pressure Independence		See Table 3.	

Table 3. Pressure Independence Range.

Action	Valve	Size	Δp_{min} (psi)	Δp_{max} (psi)
Normally Closed	599-04300	1/2 (15)	2.3	58
	599-04301		2.6	
	599-04302	3/4 (20)	2.3	
	599-04303		3.2	
	599-04304	1 (25)	3.2	
	599-04305	1-1/4 (32)	2.6	
Normally Open	599-04320	1/2 (15)	2.5	
	599-04321		3.1	
	599-04322	3/4 (20)	5.0	
	599-04323	1 (25)	3.3	
	599-04314	1-1/4 (32)	4.1	
	599-04315	1-1/2 (40)	3.6	
	599-04316	2 (50)	5.0	

Miscellaneous	Mounting location	NEMA 1 (interior only)
	Dimensions and weight	See Figure 2 and Figure 3.
Accessory	P/T port set for PICV	599-10079
	One set of high and low pressure measuring ports to replace blank caps in valves	
P/T Ports Installation	The low-pressure P/T port (blue indicator ring) should be located on the downstream side of the valve. The high-pressure P/T port (red indicator ring) will be located on the upstream or inlet side of the valve.	
	For 1/2 and 1-1/4-inch Normally Open Valves	NOTE: 1-1/2- and 2-inch Normally Open valves ship with P/T ports installed.

For 1/2 to 1-1/4-inch Normally Closed Valves

The low-pressure P/T port (blue indicator ring) should be located on the side of the valve with the raised lettering and label. The high-pressure P/T port (red indicator ring) will be located on the opposite side.

Presetting Adjustment

Prior to mounting the actuator, verify the valve is set to ordered flow setting (suffix of part number).

To change the valve flow setting, see Steps 2, 3, and 4 below (Flow setting scales are in gallons per minute [gpm] on all valves):

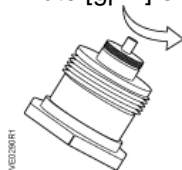

1. On 1/2- to 1-1/4-inch valves, loosen the brass knurled nut. On 1-1/2 and 2-inch valves, loosen the valve stem.
2. Adjust the desired dial setting with the white knob.
3. Retighten the brass knurled nut or valve stem by hand.

NOTE: When tightening the knurled nut on 1/2- to 1-1/4-inch valves, some force is required to reach the required physical stop; approximately an additional 1/2 3/4 extra turn after initial “finger tight” resistance is felt.



CAUTION:

On 1-1/2- and 2-inch valves, do NOT use tools to tighten the valve stem. Hand-tighten only or damage will occur.



CAUTION:

Do NOT rotate the actuator on the valve once the actuator and valve stem are connected. Doing so will inadvertently adjust the flow setting of the valve or damage the stem.

Mounting and Installation

Install the valve so the flow follows the direction of the arrow indicated on the valve body.

For best performance, install the valve assembly with the actuator above the valve body. The valve and actuator can be installed in any position between vertical and horizontal. See Figure 1.

Do not install the valve assembly with the actuator below horizontal or upside down.

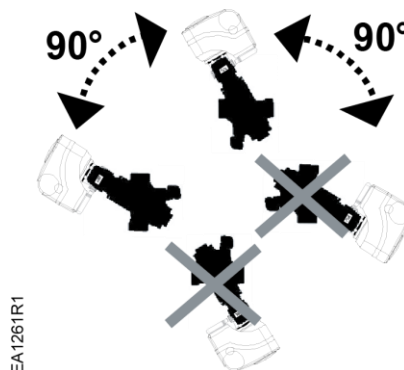

Figure 1. Recommended Installation Orientations.

NOTE: Allow enough space for servicing the valve and actuator. Instructions for field mounting an actuator, wiring diagrams, and start-up are covered in the *SSD Series Electronic Valve Actuator Installation Instructions (129-540)* and *SAY Modulating Electronic Valve Actuators Installation Instructions (129-583)*.

Commissioning Notes



CAUTION:

The Pressure Independent Control Valves must be open when flushing or pressure testing the system. Strong pressure impacts can damage closed Pressure Independent Control Valves.



CAUTION:

Differential pressure across the valve greater than 58 psi will result in damage to the pressure regulator.

Dimensions in Inches (mm)

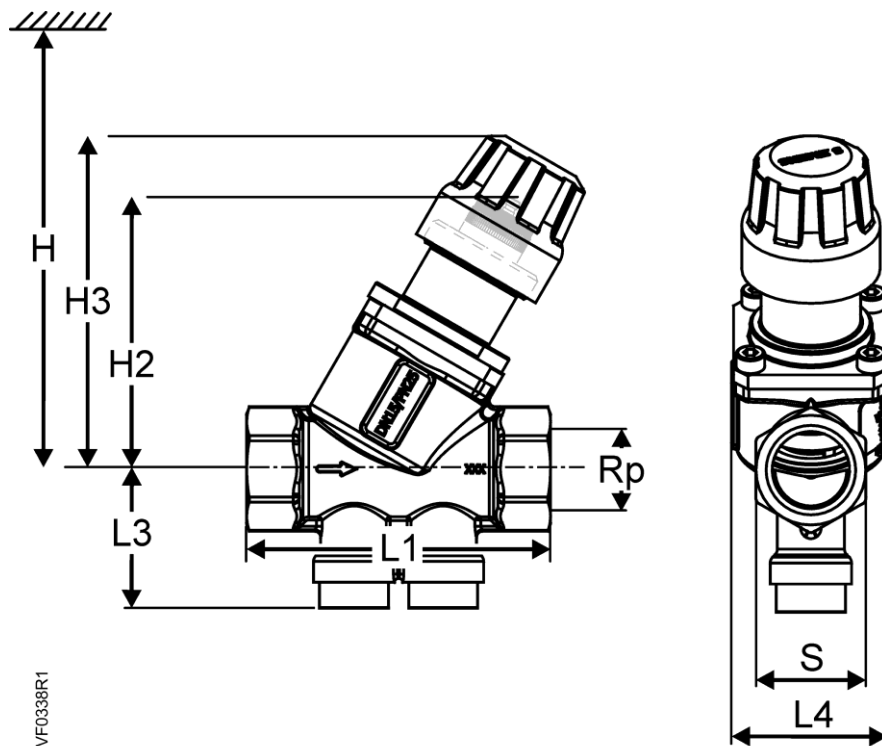

VF0338R1

Valve P/N	Valve Size Inch	S	L1	L3	L4	H2	H3	H	Weight lb (kg)
599-04320	1/2	1.1 (27)	3.0 (75)	1.6 (41)	1.5 (38)	2.6 (67.3)	3.2 (82.4)	14.6 (371)	1.1 (0.50)
599-04321									
599-04322	3/4	1.25 (32)	3.1 (79)	1.6 (41)	1.5 (38)	2.7 (67.5)	3.3 (82.5)	14.7 (374)	1.2 (0.53)
599-04323	1	1.5 (40)	4.0 (100)	1.7 (44)	2.5 (65)	3.4 (86)	4.0 (100)	15.4 (391)	2.8 (1.27)
599-04314	1-1/4	1.8 (46)	4.1 (104)	2.1 (53)	2.5 (65)	3.4 (86)	4.0 (100)	15.4 (391)	2.8 (1.27)
599-04315	1-1/2	2.3 (58)	5.4 (138)	2.7 (68)	3.7 (94)	5.9 (149)	–	20 (508)	7.2 (3.28)
599-04316	2	2.8 (72)	5.4 (138)	2.9 (74)	3.7 (94)	5.9 (149)	–	20 (508)	8.2 (3.71)

Figure 2. Two-Way Normally Open Valves Dimensions.

**Dimensions in Inches (mm),
 Continued**

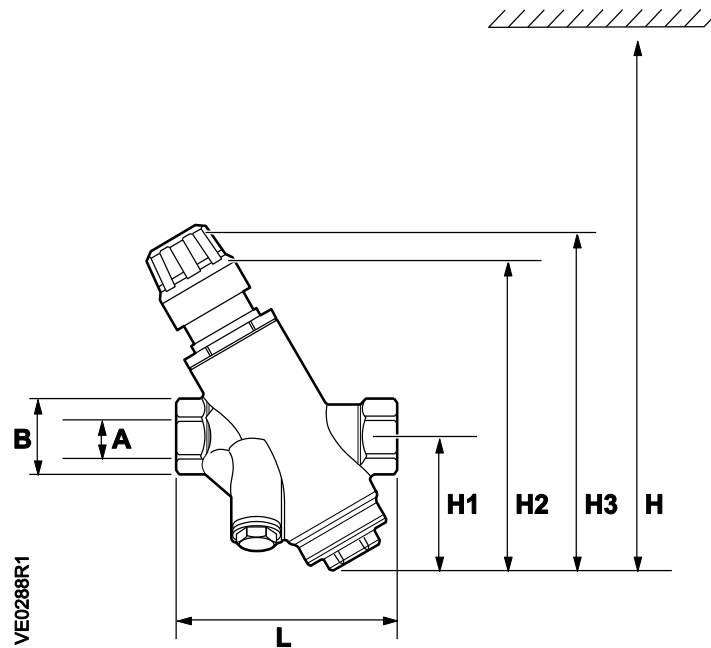

Valve P/N	Valve Size Inch	A	B	L	H1	H2	H3	H	Weight lb (kg)
599-04300	1/2	.50 (15)	1.1 (27)	3.5 (88)	2.1 (53)	4.8 (123)	5.3 (135)	16.3 (414)	2.0 (0.9)
599-04301									
599-04302	3/4	.75 (20)	1.3 (32)						
599-04303									
599-04304	1	1.0 (25)	1.5 (39)	3.6 (92)	2.7 (69)	5.7 (145)	6.2 (158)	19.9 (505)	3.3 (1.5)
599-04305	1-1/4	1.25 (32)	1.8 (46)	5.0 (128)					

Figure 3. Two-Way Normally Closed Valves Dimensions.

Information in this publication is based on current specifications. The company reserves the right to make changes in specifications and models as design improvements are introduced. Product or company names mentioned herein may be trademarks of their respective owners.
 © 2021-2023 Siemens Industry, Inc.